

LONGTECH OPTICS

Address: 5F No. 88 Sunban South Road
Jimei North Area Xiamen China.
Tel: +86-592-6060928
Fax: +86-592-6682033
E-mail: zhong@longtech-display.com

SPECIFICATIONS OF LCD MODULE

MODULE NO : LGM128128A-FSW-FBW

DOC.REVISION: 01

	SIGNATURE	DATE
PREPARED BY (RD ENGINEER)	<i>Liu</i>	2008-6-10
CHECKED BY	<i>Chen</i>	2008-6-10
APPROVED BY	<i>ye</i>	2008-6-10

DOCUMENT REVISION HISTORY

Version	DATE	DESCRIPTION	CHANGED BY
00	June-10-2008	First issue	

CONTENTS

Item	Page
Functions & Features	3
Mechanical specifications	3
Dimensional Outline	4
Absolute maximum ratings	5
Pin description	5
Optical characteristics	5
Electrical characteristics	6
Flowchart of communications with MPU	7
Command definitions	8-16
Quality Specifications	16-23

REV	DESCRIPTION:	DATE
-----	--------------	------

PIN ASSIGNMENT

1	FGND
2	VSS
3	VDD
4	V0
5	/M/R
6	/R/D
7	/C/E
8	C/D
9	/RST
10	DB0
11	DB1
12	DB2
13	DB3
14	DB4
15	DB5
16	DB6
17	DB7
18	FS
19	A
20	K

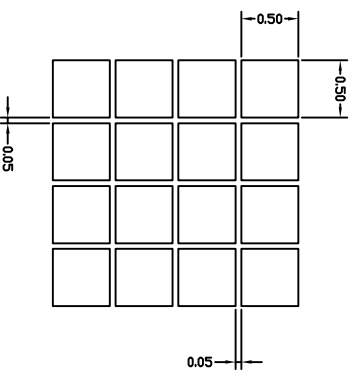
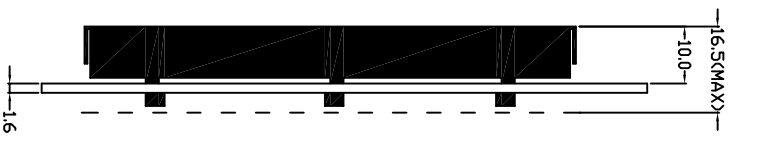
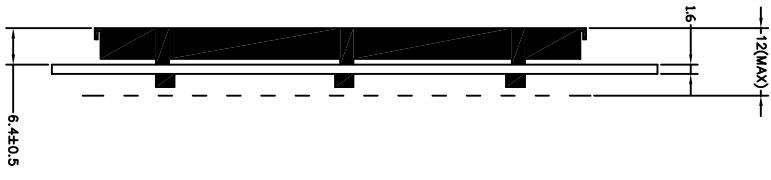
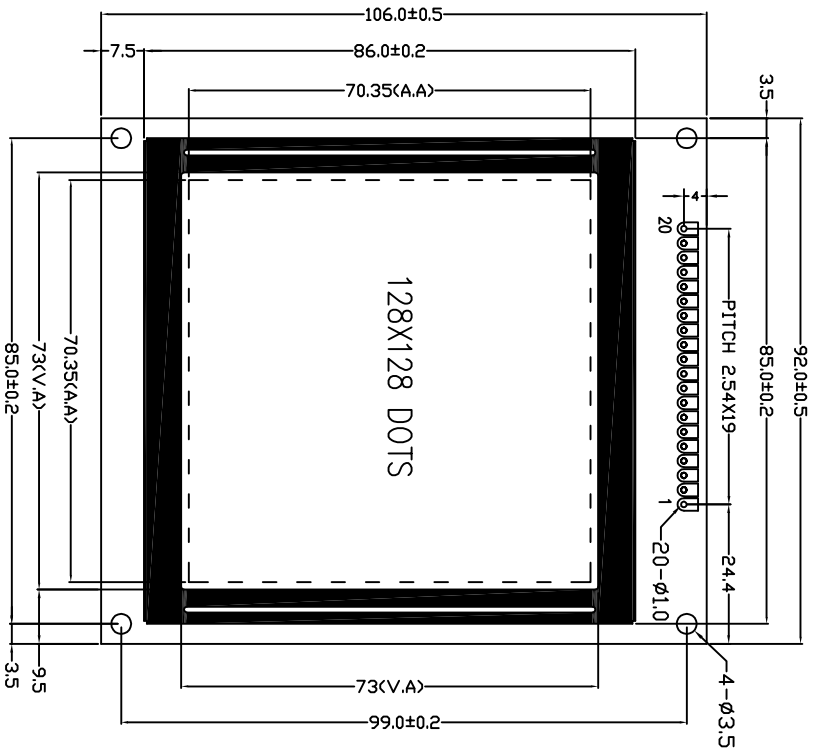

Specification:

- 1). Driving: Duty:1/128, Bias:1/12, VLCD:13.5V, VDD:5.0V
- 2). Viewing Direction: 6 O'clock
- 3). Display mode: FSTN/Positive/Transflective
- 4). Operating temp.: -20°C~+70°C
- 5). Storage temp.: -30°C~+80°C
- 6). Driver : T6963C
- 6). Backlight: Matix type/Yellow-green/4.2V

Model Name:	LGM128128A	 LONGTECH OPTICS CO., LTD.	
GENERAL TOL:	± 0.2		
APPROVALS	DATE	DRAWN NO.	SCALE:
DWN: Qiwei Qiu			1:1
CHK:		SIZE:	UNIT:
APP: Guoxiang Ye		A4	mm
			Page:
			1-1

1. Features

1. 240X128 dots
2. Built-in controller (T6963C)
3. +5.0V power supply
4. 1/128 duty cycle;1/12bias
5. BKL to be driven by pin19, pin20.

LCD type	<input type="checkbox"/> FSTN positive		<input checked="" type="checkbox"/> FSTN Negative	
	<input type="checkbox"/> STN Yellow Green	<input type="checkbox"/> STN Gray		<input type="checkbox"/> STN-Blue
View direction	<input checked="" type="checkbox"/> 6 O'clock		<input type="checkbox"/> 12 O'clock	
Rear Polarizer	<input type="checkbox"/> Reflective		<input checked="" type="checkbox"/> Transflective	<input type="checkbox"/> Transmissive
Backlight Type	VLED	<input type="checkbox"/> EL	<input type="checkbox"/> Internal Power	<input checked="" type="checkbox"/> 5.0V input
		<input type="checkbox"/> CCFL	<input type="checkbox"/> External Power	<input type="checkbox"/> 3.3 input
Backlight Color	<input checked="" type="checkbox"/> White	<input type="checkbox"/> Amber	<input type="checkbox"/> Blue-Green	<input type="checkbox"/> Yellow-Green
Temperature Range	<input checked="" type="checkbox"/> Normal		<input type="checkbox"/> Wide	<input type="checkbox"/> Super Wide
DC to DC circuit	<input checked="" type="checkbox"/> Build-in		<input type="checkbox"/> Not Build-in	
EI Driver IC	<input type="checkbox"/> Build-in		<input checked="" type="checkbox"/> Not Build-in	
Touch screen	<input type="checkbox"/> With		<input checked="" type="checkbox"/> Without	
Font type	<input type="checkbox"/> English-Jap	<input type="checkbox"/> English-Eur	<input type="checkbox"/> English-Russian	<input type="checkbox"/> other
	anese	open		

1. MECHANICAL SPECIFICATIONS

Module size	180.0mm(L)*65.0mm(W)* Max16(H)mm
Viewing area	132.0mm(L)*39.0mm(W)
Dots size	0.49mm(L)*0.49mm(W)
Dots pitch	0.52mm(L)*0.52mm(W)
Weight	Approx.

3. Absolute maximum ratings

Item	Symbol	Standard			Unit
Power voltage	$V_{DD}-V_{SS}$	0	-	5.5	V
Input voltage	V_{IN}	VSS	-	VDD	
Operating temperature range	V_{OP}	0	-	+50	
Storage temperature range	V_{ST}	-10	-	+60	

4. Block diagram

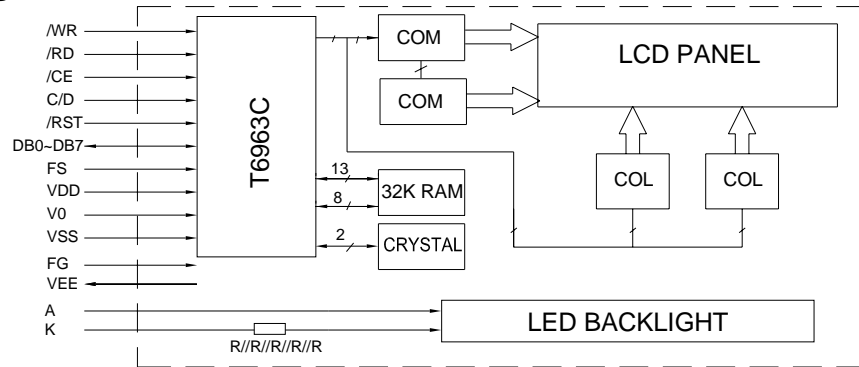

5. Interface pin description

Pin no	Symbol	External connection	Function
1	F_{GND}	Power supply	Frame ground
	V_{SS}		Signal ground for LCM (GND)
2	V_{DD}		Power supply for logic (+5V) for LCM
3	V_0		Operating voltage for LCD
4	/WR	MPU	Chip enable signal
5	/RD	MPU	Read enable signal
6	/CE	MPU	Chip enable for T6963C
7	C/D	MPU	H: Instruction L: Data
8	/RST	MPU	Reset signal
9	DB0~DB7	MPU	Data bus line
10~14	FS	MPU	Font selection
15	LED+	BKL power supply	Power supply for BKL
16	LED-		Power supply for BKL

6. Optical characteristics

F+STN type display module ($T_a=25^\circ\text{C}$, $V_{DD}=5.0\text{V}$)

Item	Symbol	Condition	Min.	Typ.	Max.	Unit
Viewing angle		C_r 2	-60	-	35	deg
			-40	-	40	
Contrast ratio	C_r	-	-	6	-	-
Response time (rise)	T_r	-	-	150	250	ms
Response time (fall)	T_r	-	-	150	250	

7. Electrical characteristics

DC characteristics

Parameter	Symbol	Conditions	Min.	Typ.	Max.	Unit
Supply voltage for LCD	V_{DD-V_0}	$T_a = 25$	-	17.5	-	V
Input voltage	V_{DD}		4.7	-	5.5	
Supply current	I_{DD}	$T_a = 25, V_{DD} = 5.0V$	-	25	-	mA
Input leakage current	I_{LKG}		-	-	1.0	uA
“H” level input voltage	V_{IH}		2.2	-	V_{DD}	V
“L” level input voltage	V_{IL}	Twice initial value or less	0	-	0.6	
“H” level output voltage	V_{OH}	LOH=-0.25mA	2.4	-	-	
“L” level output voltage	V_{OL}	LOH=1.6mA	-	-	0.4	
Backlight supply voltage	V_F		-	5.0	-	
Backlight supply current	I_F	$V = 5.0V$	-	120		mA

➤ **Switching characteristics**

($T_a = 25, V_{DD} = 5.0V$)

Item	Symbol	Test conditions	Min.	Typ.	Max.	Unit
C/D set-up time	T_{cds}	—	100	—	—	ns
C/D hold time	T_w		10	—	—	
/CE, /RD, /WR pulse width	T_{ce}, T_{rd}, T_{wr}		80	—	—	
Data set-up time	T_{ds}		80	—	—	
Data hold time	T_{dh}		40	—	—	
Access time	T_{acc}		—	—	150	
Output hold time	T_{oh}		10	—	50	

Bus timing diagram

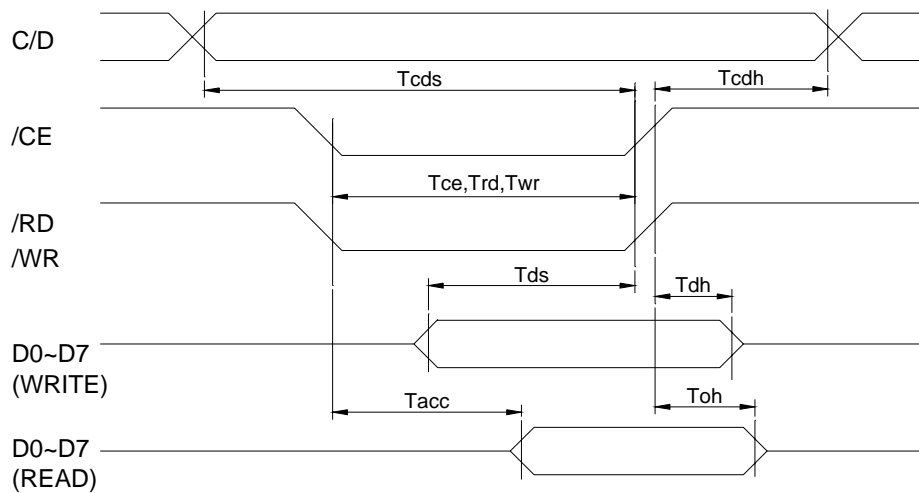

8.Flowchart of communications with MPU

Status read

A status check must be performed before data is read or written. The status word format is as follows:

/RD	/WR	/CE	C/D	STA7	STA5	STA5	STA4	STA3	STA2	STA1	STA0
0	1	0	1	DB7	DB6	DB5	DB4	DB3	DB2	DB1	DB0

STA0	Check command execution capability	0: disable	1:enable
------	------------------------------------	------------	----------

STA1	Check data read / write capability	0: disable	1:enable
STA2	Check auto mode data read capability	0: disable	1:enable
STA3	Check auto mode data write capability	0: disable	1:enable
STA4	Not used		
STA5	Check controller operation capability	0: disable	1:enable
STA6	Error flag. Used for screen peek and screen copy commands.	0: no error	1: error
STA7	Check the blink condition	0: display off	1: normal display

Notes:

1. It is necessary to check STA0 and STA1 at the same time. There is a possibility of erroneous operation due to a hardware interrupt.
2. For most modes STA0 / STA1 are used as a status check.
3. STA2 and STA3 are valid in auto mode; STA0 and STA1 are invalid.
4. When using the STA7=0 command, a status read must be performed. If a status check is not carried out, the RA8863 cannot operate normally, even after a delay time. The hardware interrupt occurs during the address calculation period (at the end of each line). If a STA7=0 command is sent to the RA8863 during this period, the RA8863 enters wait status. If a status check is not carried out in this state before the next command is sent, there is the possibility that the command or data will not be received.

Setting data

When using the RA8863, first set the data, and then set the command. Procedure for sending a command:

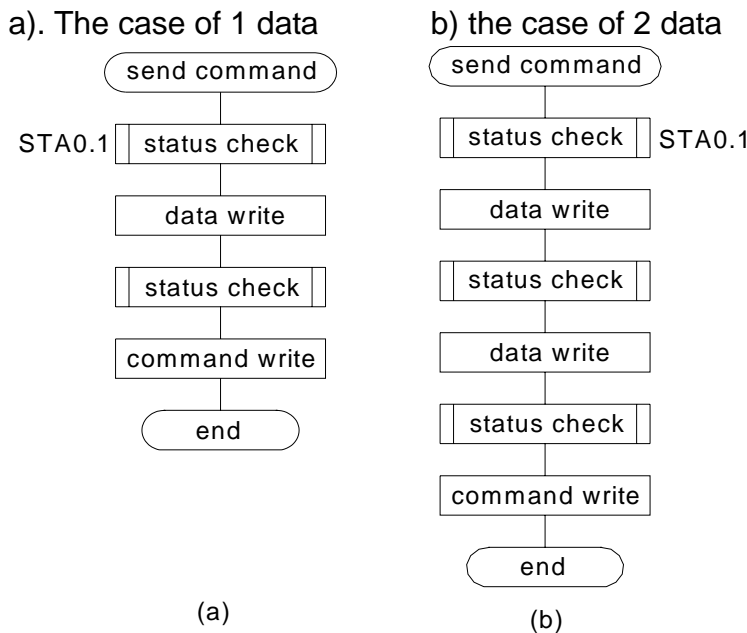

Note:

When sending more than two data, the last datum (or last two data) is valid.

9.Command definitions

Command	Code	D1	D2	Function
Registers setting	00100001	X address	Y address	Set cursor pointer
	00100010	Data	00H	Set offset register
	00100100	Low address	High address	Set address pointer
Set control word	01000000	Low address	High address	Set text home address
	01000001	columns	00H	Set text area
	01000010	Low address	High address	Set graphic home address
	01000011	columns	00H	Set graphic area

Mode set	1000X000 1000X001 1000X011 1000X100 10000XXX 10001XXX			OR mode EXOR mode AND mode Text attribute mode Internal CG ROM mode External CG RAM mode
Display mode	10010000 1001XX10 1001XX11 100101XX 100110XX 100111XX			Display off Cursor on, blink off Cursor on, blink on Text on, graphic off Text off, graphic on Text on, graphic on
Cursor pattern select	10100000 10100001 10100010 10100011 10100100 10100101 10100110 10100111			1- Line cursor 2- Line cursor 3- Line cursor 4- Line cursor 5- Line cursor 6- Line cursor 7- Line cursor 8- Line cursor
Data auto read / write	10110000 10110001 10110010			Set data auto write Set data auto read Auto reset
Data read / write	11000000 11000001 11000010 11000011 11000100 11000101	Data Data Data		Data write and increment ADP Data read and increment ADP Data write and decrement ADP Data read and decrement ADP Data write and no variable ADP Data read and no variable ADP
Screen peek	11100000			Screen peek
Screen copy	11101000			Screen copy
Bit set / reset	11110XXX 11111XXX 1111X000 1111X001 1111X010 1111X011 1111X100 1111X101 1111X110 1111X111			Bit reset Bit set Bit 0 (LSB) Bit 1 Bit 2 Bit 3 Bit 4 Bit 5 Bit 6 Bit 7(MSB)

Note:

When an MPU program with checking the busy flag (DB7) is made, it must be necessary 1/2fosc is necessary for executing the next instruction by the falling edge of the "E" signal after the busy flag (DB7) goes to "Low".

X: invalid

Contents**1). Setting registers**

D1	D2	DB7	DB6	DB5	DB4	DB3	DB2	DB1	DB0
X	X	0	0	1	0	0	N2	N1	N0

CODE	HEX.	FUNCTION	D1	D2
00100001	21H	Set cursor pointer	X ADRS	Y ADRS

00100010	22H	Set offset register	DATA	00H
00100100	24H	Set address pointer	Low ADRS	High ADRS

➤ **Set cursor pointer**

X ADRS and Y ADRS specify the position or the cursor. The cursor position can only be moved by this command. Data read / write from the MPU never changes the cursor pointer.

X ADRS and Y ADRS are specified as follows.

X ADRS 00H to 4FH (lower 7 bits are valid)

Y ADRS 00H to 1FH (lower 5 bits are valid)

a) Single-scan

X ADRS 00H to 4FH

Y ADRS 00H to 0FH

b) Dual-scan

X ADRS 00H to 4FH

Y ADRS 00H to 0FH(upper screen)

Y ADRS 10H to 1FH(lower screen)

➤ **Set offset register**

The offset register is used to determine the external character generator RAM area.

The RA8863 has a 16-bit address bus as follows:

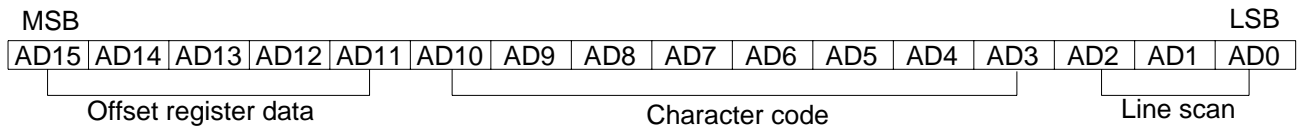

RA8863 assign external character generator, when character code set 80H to FFH in using internal character generator. Character code 00H to 80H assign External character generator, when External generator mode.

The senior five bits define the start address in external memory of the CGRAM area. The next eight bits represent the character code of the character. In internal CGRAM mode, character codes 00H to 7FH represent the predefined “internal” CGRAM characters, and codes 80H to FFH represent the user’s own “external” characters. In external CGRAM mode, all 256 codes from indicate one of the eight rows of eight dots that define the character’s shape.

The relationship between display RAM address and offset register

➤ **Set address pointer**

The set address pointer command is used to indicate the start address for writing to (or reading from) external RAM.

The flowchart for set address pointer command:

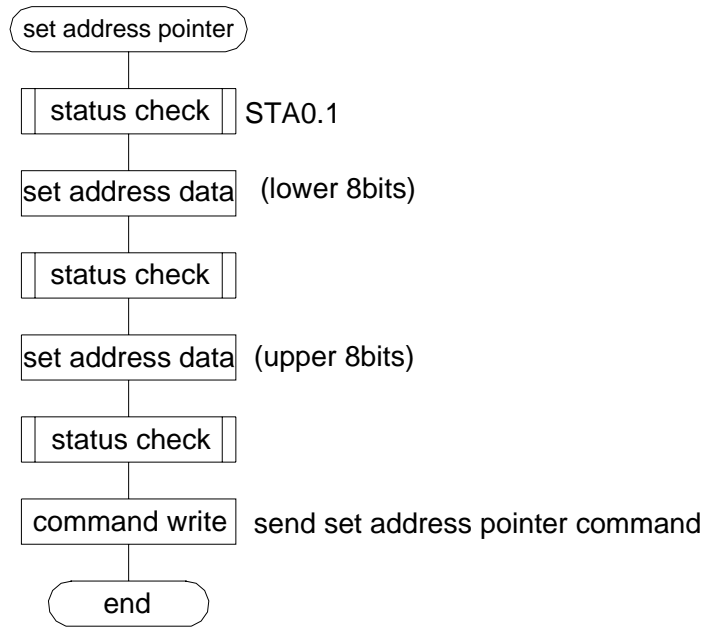

2). Set control word

D1	D2	DB7	DB6	DB5	DB4	DB3	DB2	DB1	DB0
X	X	0	1	0	0	0	0	N1	N0

CODE	HEX.	FUNCTION	D1	D2
01000000	40H	Set text home address	Low address	High address
01000001	41H	Set text area	Columns	00H
01000010	42H	Set graphic home address	Low address	High address
01000000	43H	Set graphic area	Columns	00H

The home address and column size are defined by this command.

➤ **Set text home address**

The starting address in the external display RAM for text display is defined by this command.

The text home address indicates the leftmost and uppermost position.

The relationship between external display RAM address and display position

TH		TH +CL
TH+TA		TH+TA+CL
(TH+TA)+TA		TH+2TA+CL
(TH+2TA)+TA		TH+3TA+CL
/		/
TH+(N-1) TA		TH+(N-1) TA+CL

TH: text home address

TA: text area number (columns)

CL: columns ate fixed by hardware (pin-programmable)

➤ **Set graphic home address**

The starting address of the external display RAM used for graphic display is defined by this command. The graphic home address indicates the leftmost and uppermost position.

The relationship between external display RAM address and display position

GH		GH +CL
GH+GA		GH + GA +CL
(GH+ GA)+ GA		GH +2 GA +CL
(GH +2 GA)+ GA		GH +3 GA +CL
/		/
GH +(N-1) GA		GH +(N-1) GA +CL

GH: Graphic home address

GA: Graphic area number (columns)

CL: columns ate fixed by hardware (pin-programmable)

➤ Set text area

The display columns are defined by the hardware setting. This command can be used to adjust the columns of the display.

➤ Set graphic area

The display columns are defined by the hardware setting. This command can be used to adjust the columns of the graphic display.

If the graphic area setting is set to match the desired number of columns on the LCD, the addressing scheme will be automatically modified so that the start address of each line equals the end address of the previous line +1.

3). Mode set

CODE	FUNCTION	OPERAND
1000X000	OR Mode	—
1000X001	EXOR Mode	—
1000X011	AND Mode	—
1000X100	TEXT Attribute Mode	—
10000XXX	Internal character Mode	—
10001XXX	External character Mode	—

The display mode is defined by this command. The display mode does not change until the next command is sent. The logical OR, EXOR, AND of text or graphic display can be displayed.

In internal character generator mode, character codes 00H to 7FH are assigned to the built-in character generator ROM. The character codes 80H to FFH are automatically assigned to the external character generator RAM.

NOTE: attribute functions can only be applied to text display, since the attribute data is placed in the graphic RAM area.

Attribute function

The attribute operations are reverse display, character blink and inhibit. The attribute data is written into the graphic area, which was defined by the set control word command. Only text display is possible in attribute function mode; graphic display is automatically disabled. However, the display mode command must be used to turn both text and graphic on in order for the attribute function to be available.

The attribute data for each character in the text area is written to the same address in the graphic area. The attribute function is defined as follows.

Attribute RAM 1byte

DB3	DB2	DB1	DB0	FUNCTION
0	0	0	0	Normal display

0	1	0	1	Reverse display
0	0	1	1	Inhibit display
1	0	0	0	Blink of normal display
1	1	0	1	Blink of reverse display
1	0	1	1	Blink of inhibit display

4). Display mode

CODE	FUNCTION	OPERAND
10010000	Display off	—
1001xx10	Cursor on, blink off	—
1001xx11	Cursor on, blink on	—
100101xx	Text on, graphic off	—
100110xx	Text off, graphic on	—
100111xx	Text on, graphic on	—

1	0	0	1	DB3	DB2	DB1	DB0
---	---	---	---	-----	-----	-----	-----

DB0: cursor blink on: 1 off: 0
 DB1: cursor display on: 1 off: 0
 DB2: text display on: 1 off: 0
 DB3: graphic display on: 1 off: 0

NOTE:

It is necessary to turn on “text display” and “graphic display” in the following cases.

- a) Combination of text / graphic display
- b) Attribute function

5). Cursor pattern select

CODE	FUNCTION	OPERAND
10100000	1-line cursor	
10100001	2-line cursor	
10100010	3-line cursor	
10100011	4-line cursor	
10100100	5-line cursor	
10100101	6-line cursor	
10100110	7-line cursor	
10100111	8-line cursor	

When cursor display is on, this command selects the cursor pattern in the range 1 line to 8 lines. The cursor pointer set command defines the cursor address.

6). Data auto read / write

CODE	HEX.	FUNCTION	OPERAND
10110000	B0H	Set data auto write	—

10110001	B1H	Set data auto read	—
10110010	B2H	Auto rest	—

The command is convenient for sending a full screen of data from the external display RAM. After setting auto mode, a data write (or read) command is need not be sent between each datum. A data auto write (or read) command must be send after a set address pointer command. After this command, the address pointer is automatically incremented by 1 after each datum. In auto mode, the RA8863 cannot accept any other commands.

The auto reset command must be sent to the RA8863 after all data has been sent, to clear auto mode.

NOTE: A status check for auto mode (STA2, STA3 should be checked between sending of each datum. Auto reset should be performed after checking STA3=1(STA2=1)). Refer to the following flowchart.

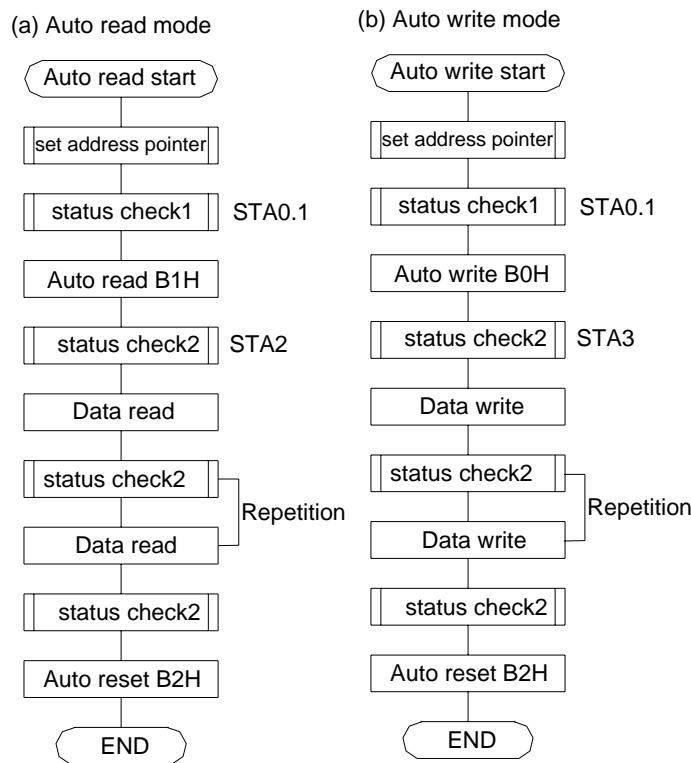

7). Data read / write

CODE	HEX.	FUNCTION	OPERAN D
11000000	C0H	Data write and increment ADP	Data
11000001	C1H	Data read and increment ADP	—
11000010	C2H	Data write and decrement ADP	Data
11000011	C3H	Data read and decrement ADP	—
11000100	C4H	Data write and no variable ADP	Data
11000101	C5H	Data read and no variable ADP	—

This command is used for writing data from the MPU to external display RAM, and reading data from external display RAM to the MPU. Data write /data read should be executed after setting address using ser address pointer command. The address pointer can be automatically incremented or decremented using this command.

Note: this command is necessary for each 1-byte datum. Refer to the following flowchart.

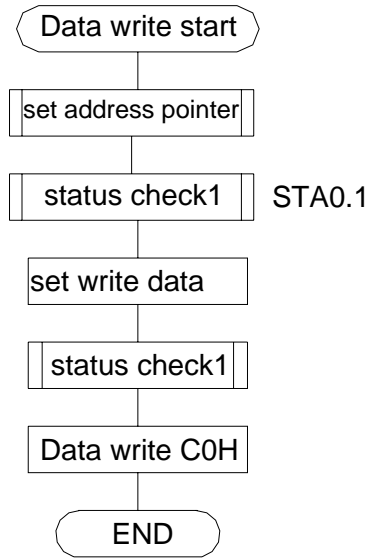

8). Screen peek

CODE	HEX.	FUNCTION	OPERAND
11100000	E0H	Screen peek	—

This command is used to transfer 1 byte of displayed data to the data stack; this byte can then be read from the MPU by data access. The logical combination of text and graphic display data on the LCD screen can be read by read by this command.

The status (STA6) should be checked just after the screen peek command. If the address determined by the set address pointer command is not in the graphic area, this command is ignored and a status flag (STA6) is set.

Refer to the following flowchart.

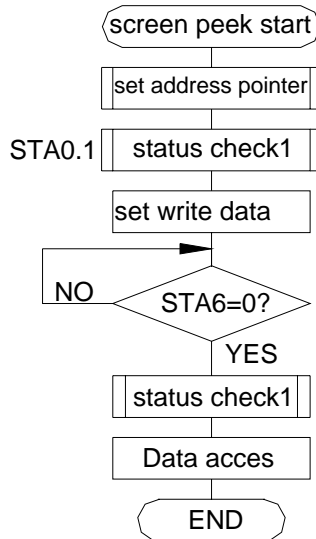

Note: this command is available when hardware column number and software column number are the same. Hardware column number is related to MD2 and MD3 setting. Software column number is related to ser text area and set graphic area command.

9). Screen copy

CODE	HEX.	FUNCTION	OPERAND
11101000	E8H	Screen copy	—

This command copies a raster line of data to the graphic area.
 The start point must be set using the set address pointer command.

Note:

If the attribute function is being used, this command is not available. (With attribute data is graphic area data.)

With dual-scan, this command cannot be used (because the RA8863 cannot separate the upper screen data and lower screen data). Refer to the following flowchart.

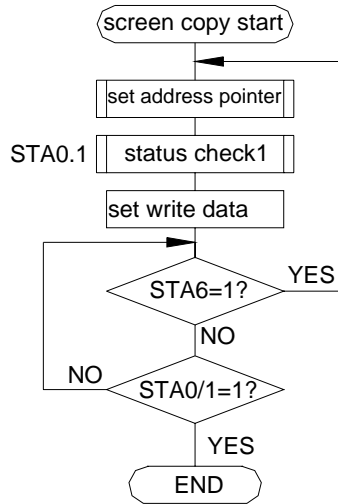

This command is available when hardware column number and software column number are the same. Hardware column number is related to MD2 and MD3 setting. Software column number is related to set text area and set graphic area command.

10). Bit set /reset

CODE	FUNCTION	OPERAND
11110XXX	Bit reset	---
11111XXX	Bit set	---
1111X000	Bit 0 (LSB0)	---
1111X001	Bit 1	---
1111X010	Bit 2	---
1111X011	Bit 3	---
1111X100	Bit 4	---
1111X101	Bit 5	---
1111X110	Bit 6	---
1111X111	Bit 7 (LSB0)	---

This command use to set or reset a bit of the byte specified by the address pointer. Only one bit can be set / reset at a time. Refer to the following flowchart.

10. QUALITY SPECIFICATIONS

10.1 Standard of the product appearance test

Manner of appearance test: The inspection should be performed in using 20W x 2 fluorescent lamps.
 Distance between LCM and fluorescent lamps should be 100 cm or more. Distance between LCM and

inspector eyes should be 30 cm or more.

Viewing direction for inspection is 45° from vertical against LCM.

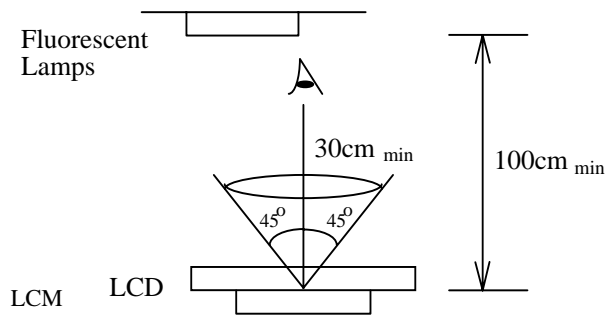

Definition of zone:

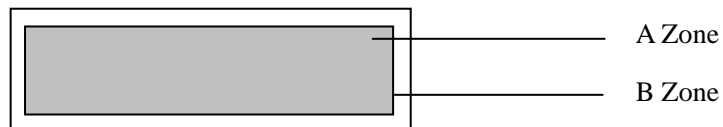

A Zone: Active display area (minimum viewing area).

B Zone: Non-active display area (outside viewing area).

10.2 Specification of quality assurance

AQL inspection standard

Sampling method: MIL-STD-105E, Level II, single sampling

Defect classification (Note: * is not including)

Classify	Item		Note	AQL
Major	Display state	Short or open circuit	1	0.65
		LC leakage		
		Flickering		
		No display		
		Wrong viewing direction		
		Contrast defect (dim, ghost)	2	
		Back-light	1,8	
	Non-display	Flat cable or pin reverse	10	
Wrong or missing component		11		
Minor	Display state	Background color deviation	2	1.0
		Black spot and dust	3	
		Line defect, Scratch	4	
		Rainbow	5	
		Chip	6	
		Pin hole	7	
		Protruded	12	
	Polarizer	Bubble and foreign material	3	
	Soldering	Poor connection	9	
	Wire	Poor connection	10	
	TAB	Position, Bonding strength	13	

Note on defect classification

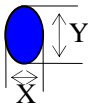
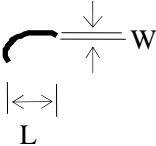
No.	Item	Criterion																				
1	Short or open circuit	Not allow																				
	LC leakage																					
	Flickering																					
	No display																					
	Wrong viewing direction																					
	Wrong Back-light																					
2	Contrast defect	Refer to approval sample																				
	Background color deviation																					
3	Point defect, Black spot, dust (including Polarizer) $\phi = (X+Y)/2$	 <table border="1" data-bbox="863 869 1299 1162"> <thead> <tr> <th>Point Size</th> <th>Acceptable Qty.</th> </tr> </thead> <tbody> <tr> <td>$\phi \leq 0.10$</td> <td>Disregard</td> </tr> <tr> <td>$0.10 < \phi \leq 0.20$</td> <td>3</td> </tr> <tr> <td>$0.20 < \phi \leq 0.25$</td> <td>2</td> </tr> <tr> <td>$0.25 < \phi \leq 0.30$</td> <td>1</td> </tr> <tr> <td>$\phi > 0.30$</td> <td>0</td> </tr> </tbody> </table> <p style="text-align: right;">Unit : mm</p>	Point Size	Acceptable Qty.	$\phi \leq 0.10$	Disregard	$0.10 < \phi \leq 0.20$	3	$0.20 < \phi \leq 0.25$	2	$0.25 < \phi \leq 0.30$	1	$\phi > 0.30$	0								
Point Size	Acceptable Qty.																					
$\phi \leq 0.10$	Disregard																					
$0.10 < \phi \leq 0.20$	3																					
$0.20 < \phi \leq 0.25$	2																					
$0.25 < \phi \leq 0.30$	1																					
$\phi > 0.30$	0																					
4	Line defect, Scratch	 <table border="1" data-bbox="791 1301 1342 1556"> <thead> <tr> <th colspan="2">Line</th> <th>Acceptable Qty.</th> </tr> <tr> <th>L</th> <th>W</th> <th></th> </tr> </thead> <tbody> <tr> <td>---</td> <td>$0.015 \leq W$</td> <td>Disregard</td> </tr> <tr> <td>3.0 L</td> <td>$0.03 \leq W$</td> <td rowspan="2">2</td> </tr> <tr> <td>2.0 L</td> <td>$0.05 \leq W$</td> </tr> <tr> <td>1.0 L</td> <td>$0.1 > W$</td> <td>1</td> </tr> <tr> <td>---</td> <td>$0.05 < W$</td> <td>Applied as point defect</td> </tr> </tbody> </table> <p style="text-align: right;">Unit: mm</p>	Line		Acceptable Qty.	L	W		---	$0.015 \leq W$	Disregard	3.0 L	$0.03 \leq W$	2	2.0 L	$0.05 \leq W$	1.0 L	$0.1 > W$	1	---	$0.05 < W$	Applied as point defect
Line		Acceptable Qty.																				
L	W																					
---	$0.015 \leq W$	Disregard																				
3.0 L	$0.03 \leq W$	2																				
2.0 L	$0.05 \leq W$																					
1.0 L	$0.1 > W$	1																				
---	$0.05 < W$	Applied as point defect																				
5	Rainbow	Not more than two color changes across the viewing area.																				

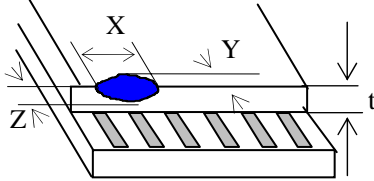
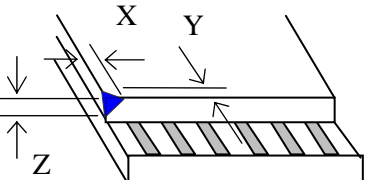
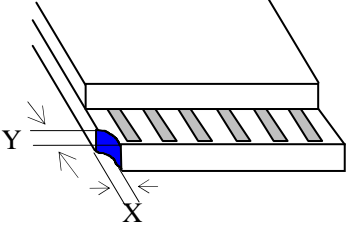
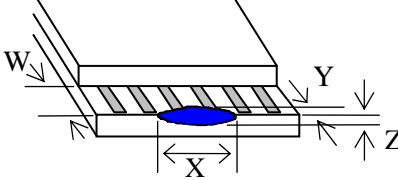
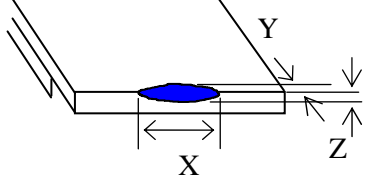
No	Item	Criterion								
6 Chip Remark: X: Length direction Y: Short direction Z: Thickness direction t: Glass thickness W: Terminal Width		Acceptable criterion <table border="1" data-bbox="933 324 1324 403"> <thead> <tr> <th>X</th> <th>Y</th> <th>Z</th> </tr> </thead> <tbody> <tr> <td>2</td> <td>0.5mm</td> <td>t/2</td> </tr> </tbody> </table>	X	Y	Z	2	0.5mm	t/2		
	X	Y	Z							
	2	0.5mm	t/2							
		Acceptable criterion <table border="1" data-bbox="925 638 1332 716"> <thead> <tr> <th>X</th> <th>Y</th> <th>Z</th> </tr> </thead> <tbody> <tr> <td>2</td> <td>0.5mm</td> <td>t</td> </tr> </tbody> </table>	X	Y	Z	2	0.5mm	t		
	X	Y	Z							
2	0.5mm	t								
	Acceptable criterion <table border="1" data-bbox="941 929 1332 1041"> <thead> <tr> <th>X</th> <th>Y</th> <th>Z</th> </tr> </thead> <tbody> <tr> <td>3</td> <td>2</td> <td>t</td> </tr> <tr> <td colspan="2">shall not reach to ITO</td> <td></td> </tr> </tbody> </table>	X	Y	Z	3	2	t	shall not reach to ITO		
X	Y	Z								
3	2	t								
shall not reach to ITO										
	Acceptable criterion <table border="1" data-bbox="925 1310 1332 1388"> <thead> <tr> <th>X</th> <th>Y</th> <th>Z</th> </tr> </thead> <tbody> <tr> <td>Disregard</td> <td>0.2</td> <td>t</td> </tr> </tbody> </table>	X	Y	Z	Disregard	0.2	t			
X	Y	Z								
Disregard	0.2	t								
	Acceptable criterion <table border="1" data-bbox="925 1590 1300 1668"> <thead> <tr> <th>X</th> <th>Y</th> <th>Z</th> </tr> </thead> <tbody> <tr> <td>5</td> <td>2</td> <td>t/3</td> </tr> </tbody> </table>	X	Y	Z	5	2	t/3			
X	Y	Z								
5	2	t/3								

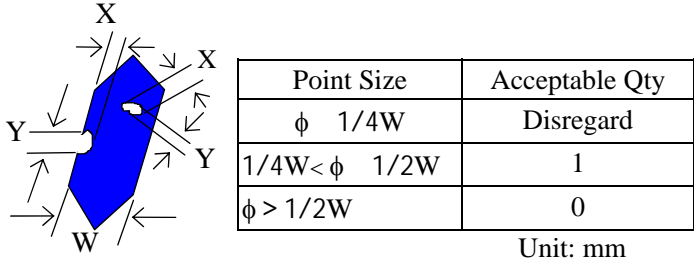
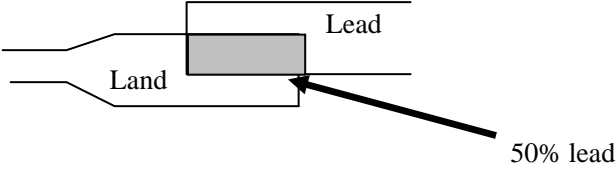
No.	Item	Criterion								
7	Segment pattern $W = \text{Segment width}$ $\phi = (X+Y)/2$	(1) Pin hole $\phi < 0.10\text{mm}$ is acceptable.  <table border="1" data-bbox="855 465 1316 633"> <thead> <tr> <th>Point Size</th> <th>Acceptable Qty</th> </tr> </thead> <tbody> <tr> <td>$\phi < 1/4W$</td> <td>Disregard</td> </tr> <tr> <td>$1/4W < \phi < 1/2W$</td> <td>1</td> </tr> <tr> <td>$\phi > 1/2W$</td> <td>0</td> </tr> </tbody> </table> Unit: mm	Point Size	Acceptable Qty	$\phi < 1/4W$	Disregard	$1/4W < \phi < 1/2W$	1	$\phi > 1/2W$	0
Point Size	Acceptable Qty									
$\phi < 1/4W$	Disregard									
$1/4W < \phi < 1/2W$	1									
$\phi > 1/2W$	0									
8	Back-light	(1) The color of backlight should correspond its specification. (2) Not allow flickering								
9	Soldering	(1) Not allow heavy dirty and solder ball on PCB. (The size of dirty refer to point and dust defect) (2) Over 50% of lead should be soldered on Land. 								
10	Wire	(1) Copper wire should not be rusted (2) Not allow crack on copper wire connection. (3) Not allow reversing the position of the flat cable. (4) Not allow exposed copper wire inside the flat cable.								
11*	PCB	(1) Not allow screw rust or damage. (2) Not allow missing or wrong putting of component.								

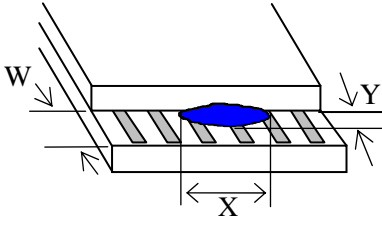
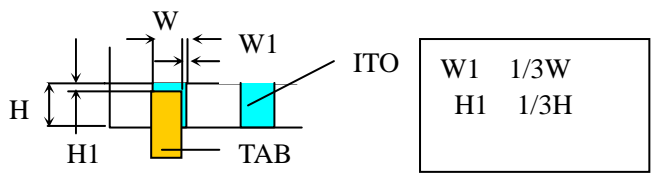
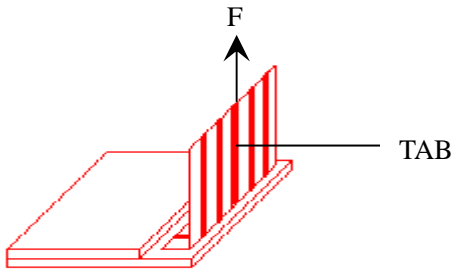
No	Item	Criterion
12	Protruded W: Terminal Width	 <p>Acceptable criteria: $Y \leq 0.4$</p>
13	TAB	<p>1. Position</p>  <p>2. TAB bonding strength test</p>  <p> $P (=F/TAB \text{ bonding width}) \quad 650gf/cm$,(speed rate: 1mm/min) 5pcs per SOA (shipment) </p>
14	Total no. of acceptable Defect	<p>A. Zone</p> <p>Maximum 2 minor non-conformities per one unit. Defect distance: each point to be separated over 10mm</p> <p>B. Zone</p> <p>It is acceptable when it is no trouble for quality and assembly in customer's end product.</p>

10.3 Reliability of LCM

Reliability test condition:

Item	Condition	Time (hrs)	Assessment
High temp. Storage	80°C	48	No abnormalities in functions and appearance
High temp. Operating	70°C	48	
Low temp. Storage	-30°C	48	
Low temp. Operating	-20°C	48	
Humidity	40°C/ 90%RH	48	
Temp. Cycle	0°C ← 25°C → 50°C (30 min ← 5 min → 30min)	10cycles	

Recovery time should be 24 hours minimum. Moreover, functions, performance and appearance shall be free from remarkable deterioration within 50,000 hours under ordinary operating and storage conditions room temperature (20±8°C), normal humidity (below 65% RH), and in the area not exposed to direct sun light.

10.4 Precaution for using LCD/LCM

LCD/LCM is assembled and adjusted with a high degree of precision. Do not attempt to make any alteration or modification. The followings should be noted.

General Precautions:

1. LCD panel is made of glass. Avoid excessive mechanical shock or applying strong pressure onto the surface of display area.
2. The polarizer used on the display surface is easily scratched and damaged. Extreme care should be taken when handling. To clean dust or dirt off the display surface, wipe gently with cotton, or other soft material soaked with isopropyl alcohol, ethyl alcohol or trichlorotrifluoroethane, do not use water, ketone or aromatics and never scrub hard.
3. Do not tamper in any way with the tabs on the metal frame.
4. Do not make any modification on the PCB without consulting LONGTECH
5. When mounting a LCM, make sure that the PCB is not under any stress such as bending or twisting. Elastomer contacts are very delicate and missing pixels could result from slight dislocation of any of the elements.
6. Avoid pressing on the metal bezel, otherwise the elastomer connector could be deformed and lose contact, resulting in missing pixels and also cause rainbow on the display.
7. Be careful not to touch or swallow liquid crystal that might leak from a damaged cell. Any liquid crystal adheres to skin or clothes, wash it off immediately with soap and water.

Static Electricity Precautions:

1. CMOS-LSI is used for the module circuit; therefore operators should be grounded whenever he/she comes into contact with the module.
2. Do not touch any of the conductive parts such as the LSI pads; the copper leads on the PCB and the interface terminals with any parts of the human body.
3. Do not touch the connection terminals of the display with bare hand; it will cause disconnection or defective insulation of terminals.
4. The modules should be kept in anti-static bags or other containers resistant to static for storage.
5. Only properly grounded soldering irons should be used.
6. If an electric screwdriver is used, it should be grounded and shielded to prevent sparks.
7. The normal static prevention measures should be observed for work clothes and working benches.
8. Since dry air is inductive to static, a relative humidity of 50-60% is recommended.

Soldering Precautions:

1. Soldering should be performed only on the I/O terminals.
2. Use soldering irons with proper grounding and no leakage.
3. Soldering temperature: $280^{\circ}\text{C}\pm 10^{\circ}\text{C}$
4. Soldering time: 3 to 4 second.
5. Use eutectic solder with resin flux filling.
6. If flux is used, the LCD surface should be protected to avoid spattering flux.
7. Flux residue should be removed.

Operation Precautions:

1. The viewing angle can be adjusted by varying the LCD driving voltage V_o .
2. Since applied DC voltage causes electro-chemical reactions, which deteriorate the display, the applied pulse waveform should be a symmetric waveform such that no DC component remains. Be sure to use the specified operating voltage.
3. Driving voltage should be kept within specified range; excess voltage will shorten display life.
4. Response time increases with decrease in temperature.
5. Display color may be affected at temperatures above its operational range.
6. Keep the temperature within the specified range usage and storage. Excessive temperature and humidity could cause polarization degradation, polarizer peel-off or generate bubbles.
7. For long-term storage over 40°C is required, the relative humidity should be kept below 60%, and avoid direct sunlight.

Limited Warranty

LONGTECH LCDs and modules are not consumer products, but may be incorporated by LONGTECH's customers into consumer products or components thereof, LONGTECH does not warrant that its LCDs and components are fit for any such particular purpose.

1. The liability of LONGTECH is limited to repair or replacement on the terms set forth below. LONGTECH will not be responsible for any subsequent or consequential events or injury or damage to any personnel or user including third party personnel and/or user. Unless otherwise agreed in writing between LONGTECH and the customer, LONGTECH will only replace or repair any of its LCD which is found defective electrically or visually when inspected in accordance with LONGTECH general LCD inspection standard . (Copies available on request)
2. No warranty can be granted if any of the precautions state in handling liquid crystal display above has been disregarded. Broken glass, scratches on polarizer mechanical damages as well as defects that are caused accelerated environment tests are excluded from warranty.
3. In returning the LCD/LCM, they must be properly packaged; there should be detailed description of the failures or defect.